

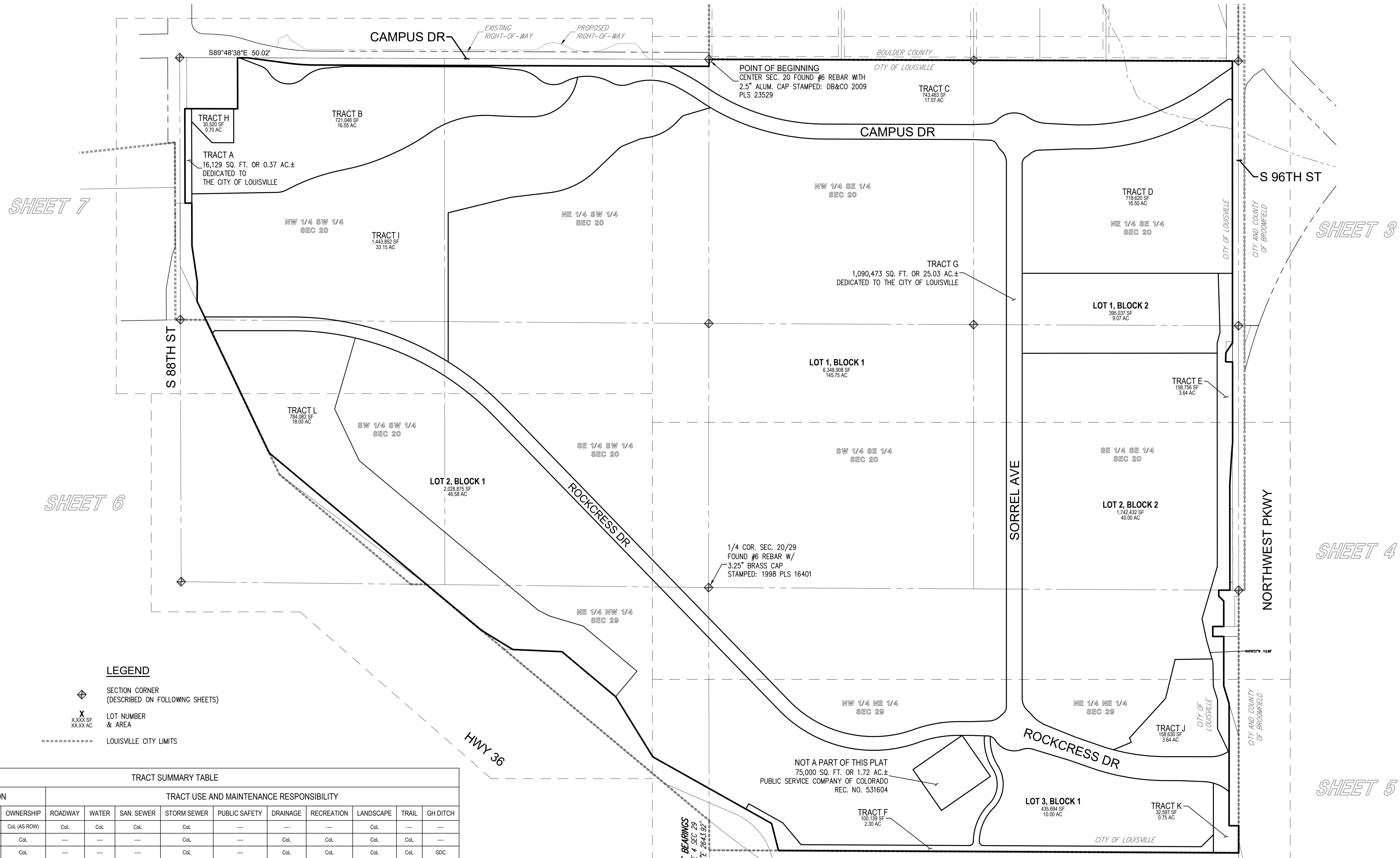

FINAL SUBDIVISION PLAT OF  
**REDTAIL RIDGE FILING NO. 1**  
 SITUATED IN THE SOUTH HALF OF SECTION 20 AND THE NORTH HALF OF SECTION 29, TOWNSHIP 1 SOUTH,  
 RANGE 69 WEST OF THE SIXTH PRINCIPAL MERIDIAN, CITY OF LOUISVILLE, COUNTY OF BOULDER, STATE OF COLORADO  
 KEY MAP/TRACT SUMMARY TABLE

PREPARED BY:  
**HKS HARRIS KOCHER SMITH**  
 1120 Lincoln Street, Suite 1000  
 Denver, Colorado 80203  
 P: 303-623-6300 F: 303-623-6311  
 HarrisKocherSmith.com



**LEGEND**

- ◆ SECTION CORNER (DESCRIBED ON FOLLOWING SHEETS)
- X LOT NUMBER & AREA (e.g., X100X SF, XXXX AC)
- LOUISVILLE CITY LIMITS

TRACT INFORMATION		TRACT USE AND MAINTENANCE RESPONSIBILITY											
TRACT	AREA (SF)	AREA (AC)	OWNERSHIP	ROADWAY	WATER	SAN. SEWER	STORM SEWER	PUBLIC SAFETY	DRAINAGE	RECREATION	LANDSCAPE	TRAIL	GH DITCH
TRACT A	16,129	0.37	Col. (AS ROW)	Col.	Col.	Col.	Col.	---	---	---	Col.	---	---
TRACT B	721,046	16.55	Col.	---	---	---	Col.	---	Col.	Col.	Col.	Col.	---
TRACT C	743,463	17.07	Col.	---	---	---	Col.	---	Col.	Col.	Col.	Col.	GDC
TRACT D	718,620	16.50	Col.	---	---	---	RRMD	---	Col/RRMD	Col.	Col.	Col.	GDC
TRACT E	158,756	3.64	Col.	---	Col.	Col.	RRMD	---	RRMD	Col.	Col.	Col.	---
TRACT F	100,139	2.30	Col. (AS ROW)	---	---	---	---	---	---	Col.	Col.	Col.	---
TRACT G	1,090,473	25.03	Col. (AS ROW)	Col.	Col.	Col.	Col/RRMD	---	Col.	---	RRMD	---	GDC
TRACT H	30,520	0.70	LFPD	---	---	---	---	LFPD	---	Col.	Col.	---	---
TRACT I	1,443,852	33.15	Col.	---	---	---	Col/RRMD	---	Col/RRMD	Col.	Col.	Col.	---
TRACT J	158,630	3.64	RRMD	---	---	---	RRMD	---	RRMD	---	RRMD	---	---
TRACT K	32,597	0.75	Col.	---	Col.	Col.	---	---	Col.	---	Col.	Col.	---
TRACT L	784,082	18.00	Col.	---	---	---	Col.	---	Col.	Col.	---	Col.	---

**ABBREVIATION LEGEND**

- Col. CITY OF LOUISVILLE
- RRMD REDTAIL RIDGE METRO DISTRICT
- GDC GOODHUE DITCH COMPANY
- LFPD LOUISVILLE FIRE PROTECTION DISTRICT

**NOTES**

- TRACTS ARE ENCUMBERED BY PROPOSED AND EXISTING EASEMENTS THAT ALLOW FOR ADDITIONAL USES.
- THIS TRACT SUMMARY TABLE IS INTENDED TO COMMUNICATE THE GENERAL USES AND MAINTENANCE RESPONSIBILITIES ASSOCIATED WITH THE TRACTS. THE FILING 1 SIDEVELOPMENT AGREEMENT SHALL BE REFERRED TO FOR ADDITIONAL DETAIL.

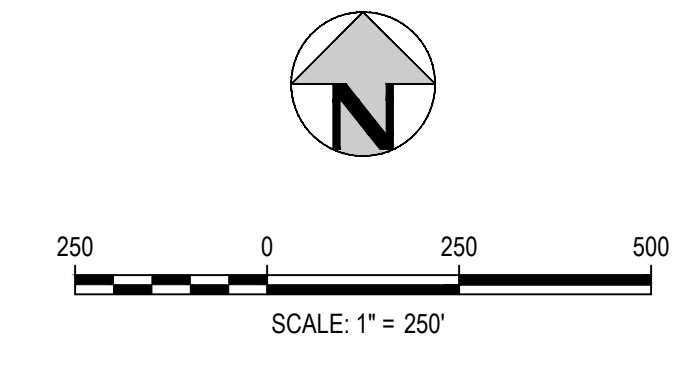

NO CHANGES ARE TO BE MADE TO THIS DRAWING WITHOUT WRITTEN PERMISSION OF HARRIS KOCHER SMITH. PROJECT NUMBER: 190108

FINAL SUBDIVISION PLAT OF  
**REDTAIL RIDGE FILING NO. 1**  
 SITUATED IN THE SOUTH HALF OF SECTION 20 AND THE NORTH HALF OF SECTION 29, TOWNSHIP 1 SOUTH,  
 RANGE 69 WEST OF THE SIXTH PRINCIPAL MERIDIAN, CITY OF LOUISVILLE, COUNTY OF BOULDER, STATE OF COLORADO  
 PLAT SHEET

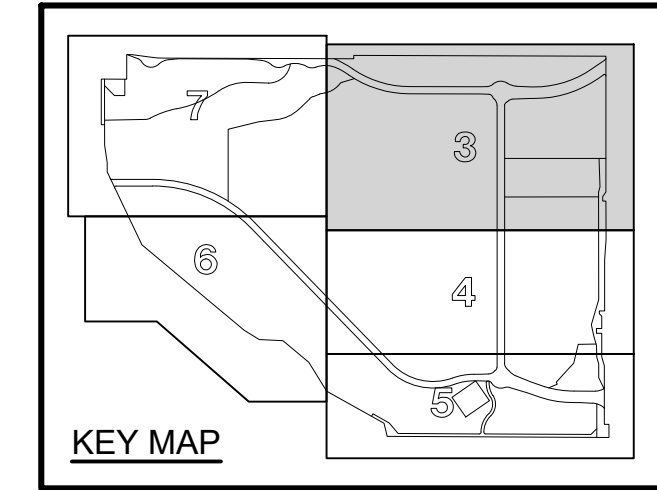

PREPARED BY:  
**HKS HARRIS KOCHER SMITH**  
 1120 Lincoln Street, Suite 1000  
 Denver, Colorado 80203  
 P: 303-623-6300 F: 303-623-6311  
 HarrisKocherSmith.com

NO CHANGES ARE TO BE MADE TO THIS DRAWING WITHOUT WRITTEN PERMISSION OF HARRIS KOCHER SMITH.

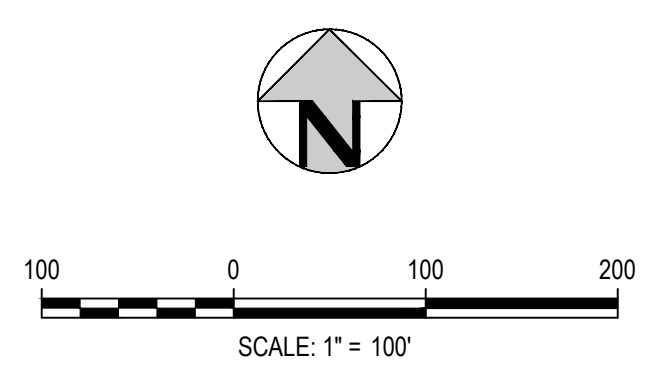
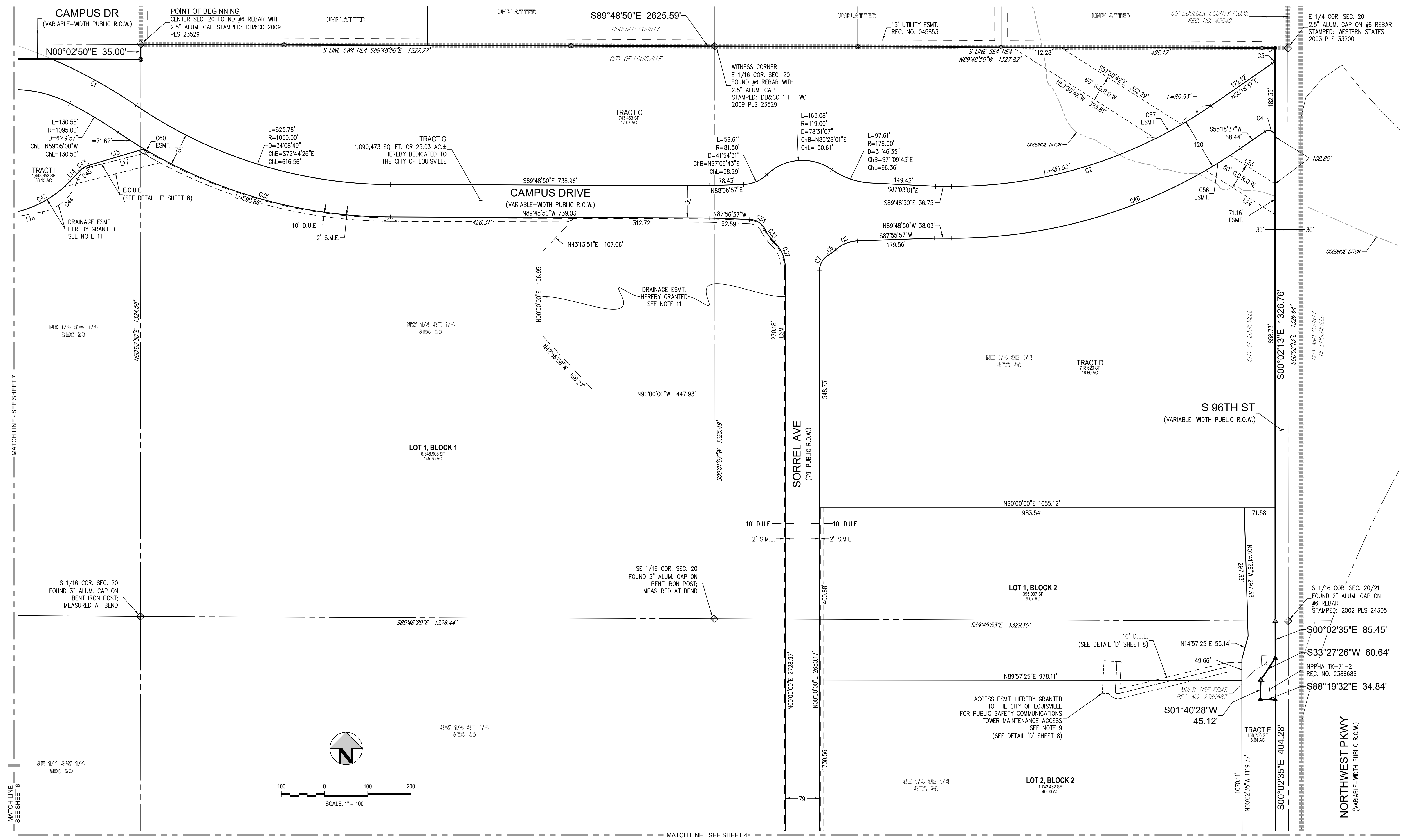

FILEPATH: P:\190108\SUBDIVISION\PLAT\190108.DWG TO DELETE DURING LAYOUT: SHT 3  
 5/2/2016 10:00:00 AM User: hks\jls Date: 5/2/2016 10:00:00 AM P: hks\jls  
 PLOT DATE: 5/2/2016 10:00:00 AM PLOT TIME: 10:00:00 AM PLOT USER: hks\jls



FINAL SUBDIVISION PLAT OF

# REDTAIL RIDGE FILING NO. 1

SITUATED IN THE SOUTH HALF OF SECTION 20 AND THE NORTH HALF OF SECTION 29, TOWNSHIP 1 SOUTH, RANGE 69 WEST OF THE SIXTH PRINCIPAL MERIDIAN, CITY OF LOUISVILLE, COUNTY OF BOULDER, STATE OF COLORADO  
PLAT SHEET

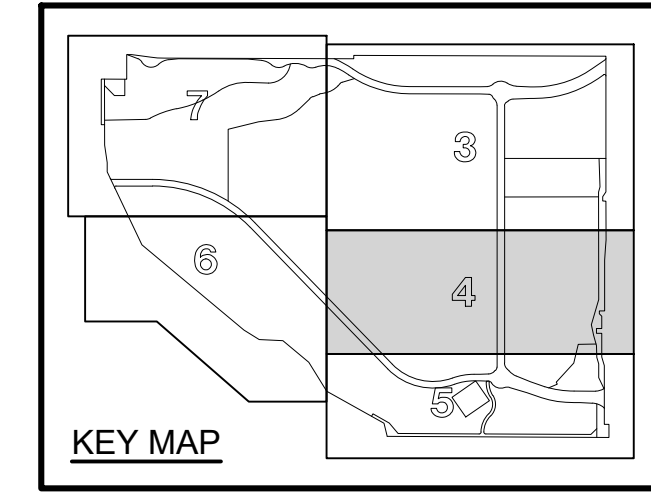

PREPARED BY:

**HKS** HARRIS KOCHER SMITH  
1120 Lincoln Street, Suite 1000  
Denver, Colorado 80203  
P: 303-623-6300 F: 303-623-6311  
HarrisKocherSmith.com

NO CHANGES ARE TO BE MADE TO THIS DRAWING WITHOUT WRITTEN PERMISSION OF HARRIS KOCHER SMITH.

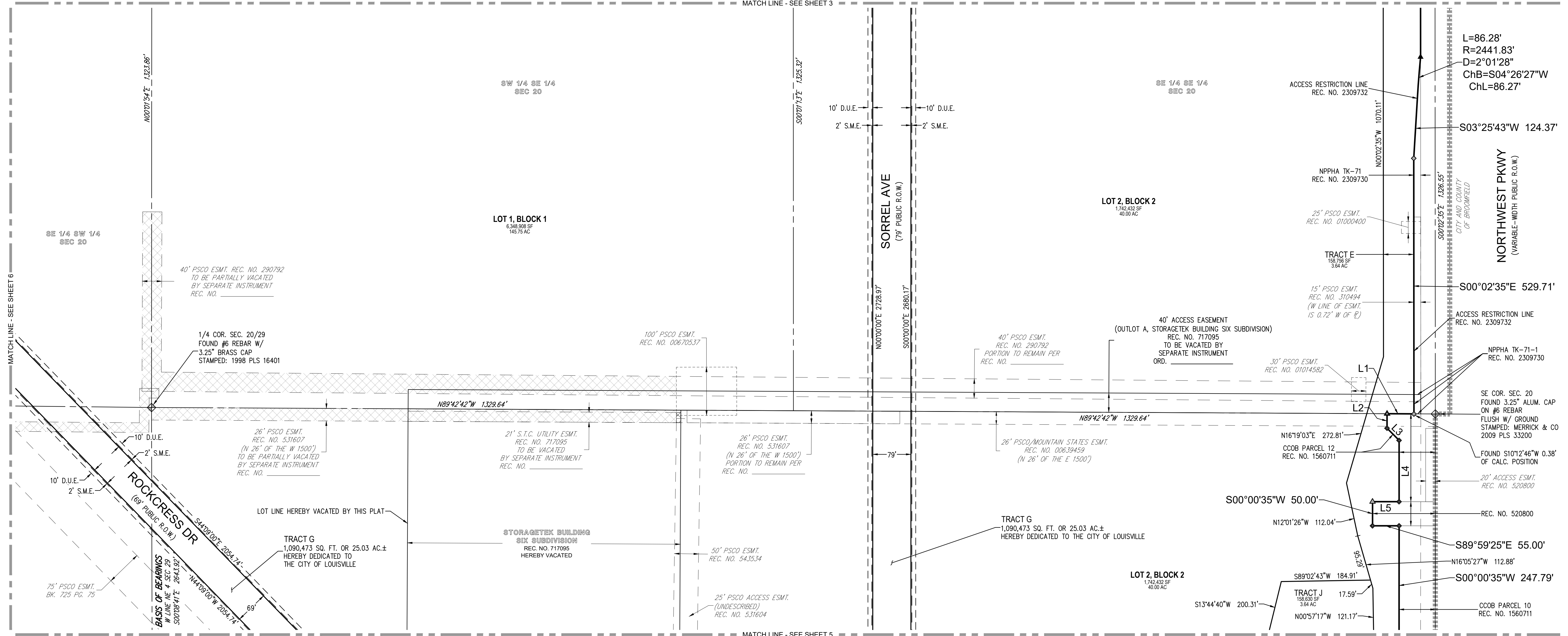

L=86.28'  
R=2441.83'  
D=2°01'28"  
ChB=S04°26'27"W  
ChL=86.27'  
S03°25'43"W 124.37'  
NORTHWEST PKWY  
(VARIABLE-WIDTH PUBLIC R.O.W.)

S00°02'35"E 529.71'  
ACCESS RESTRICTION LINE  
REC. NO. 2309732  
NPPHA TK-71-1  
REC. NO. 2309730

SE COR. SEC. 20  
FOUND 3.25" ALUM. CAP  
ON #6 REBAR  
FLUSH W/ GROUND  
STAMPED: MERRICK & CO  
2009 PLS 33200  
FOUND S10°12'46"W 0.38'  
OF CALC. POSITION  
20' ACCESS ESMT.  
REC. NO. 520800  
REC. NO. 520800  
S89°59'25"E 55.00'  
N16°05'27"W 112.88'  
S00°00'35"W 247.79'  
CCOB PARCEL 10  
REC. NO. 1560711

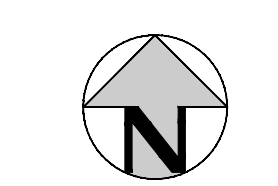

SCALE: 1" = 100'

FINAL PLAT - SHEET 4 OF 9

FILEPATH: P:\180108\REVIEWS\PLAT\180108\ENG TO DELETE\DWG LAYOUT\_SHT 4  
5\_VRBF.plt (rev 02/10) User: bsm  
PLOT: P:\180108\REVIEWS\PLAT\180108\ENG TO DELETE\DWG LAYOUT\_SHT 4  
PLOT DATE: 02/23/2024 12:28:23 PM  
PROJECT NUMBER: 180108

FINAL SUBDIVISION PLAT OF  
**REDTAIL RIDGE FILING NO. 1**  
 SITUATED IN THE SOUTH HALF OF SECTION 20 AND THE NORTH HALF OF SECTION 29, TOWNSHIP 1 SOUTH,  
 RANGE 69 WEST OF THE SIXTH PRINCIPAL MERIDIAN, CITY OF LOUISVILLE, COUNTY OF BOULDER, STATE OF COLORADO  
 PLAT SHEET/EASEMENT DETAILS 'A' & 'B'

PREPARED BY:  
**HKS HARRIS KOCHER SMITH**  
 1120 Lincoln Street, Suite 1000  
 Denver, Colorado 80203  
 P: 303-623-6300 F: 303-623-6311  
 HarrisKocherSmith.com

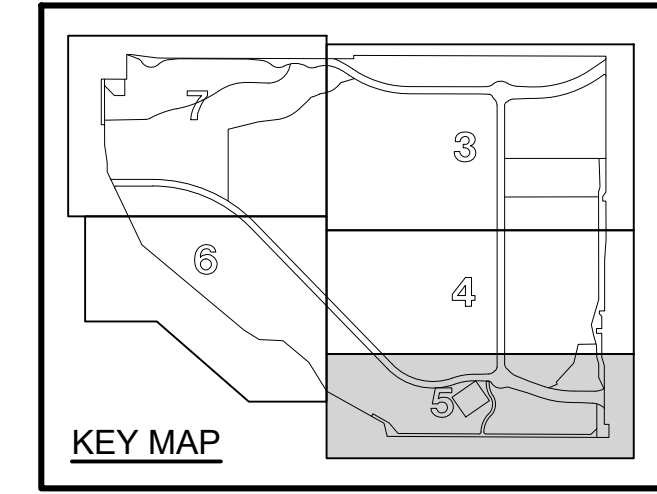

NO CHANGES ARE TO BE MADE TO THIS DRAWING WITHOUT WRITTEN PERMISSION OF HARRIS KOCHER SMITH.

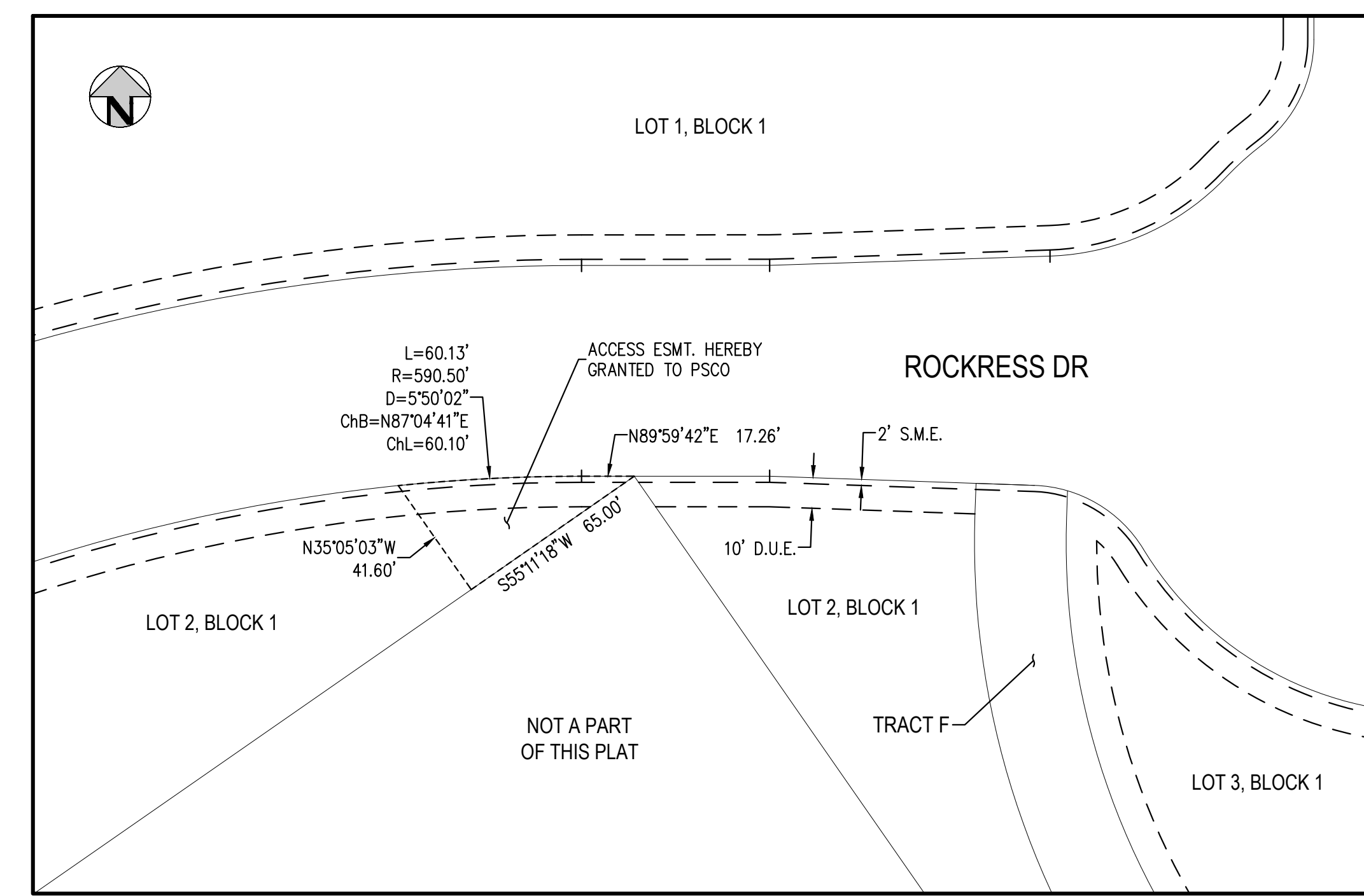
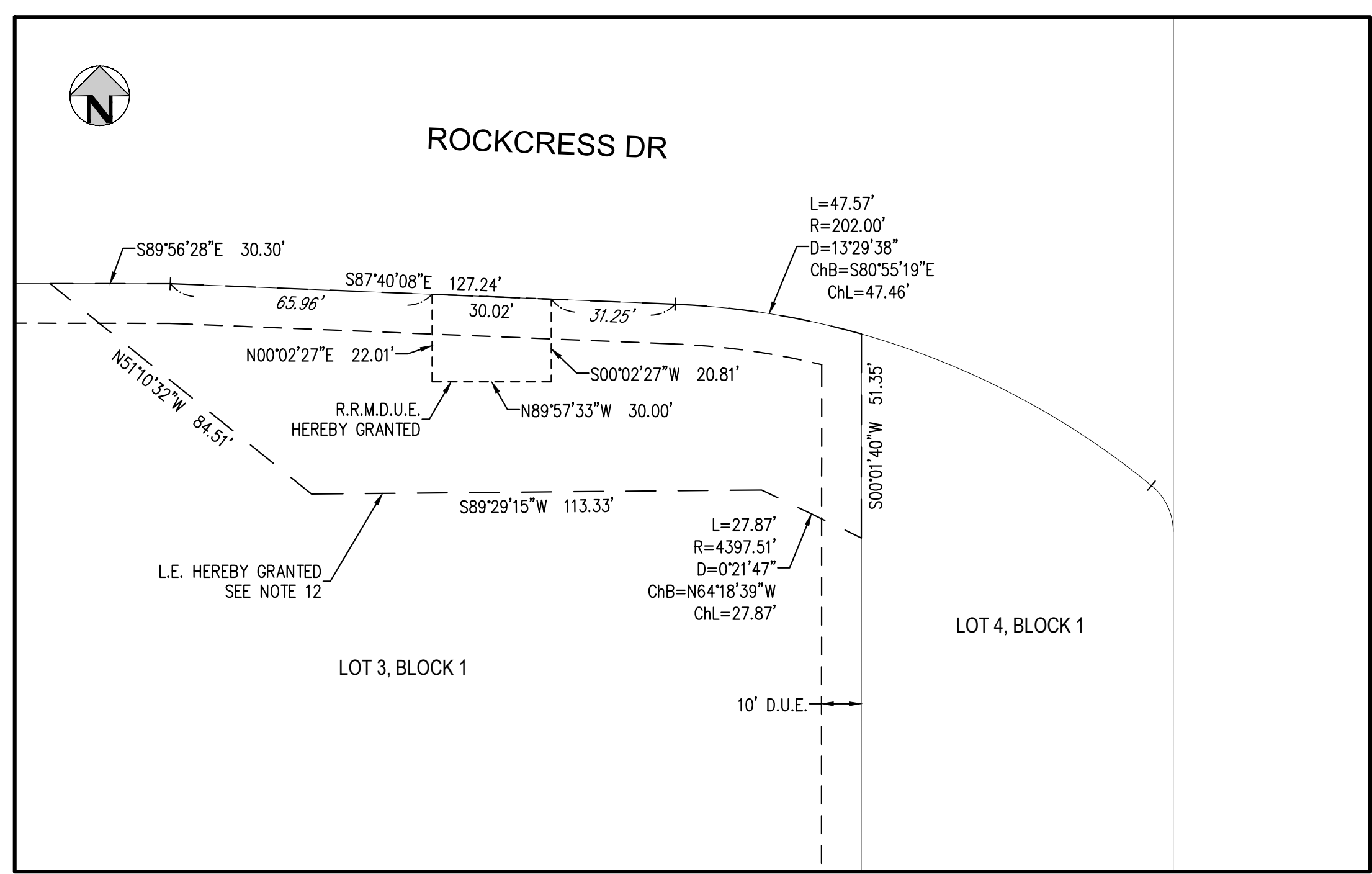
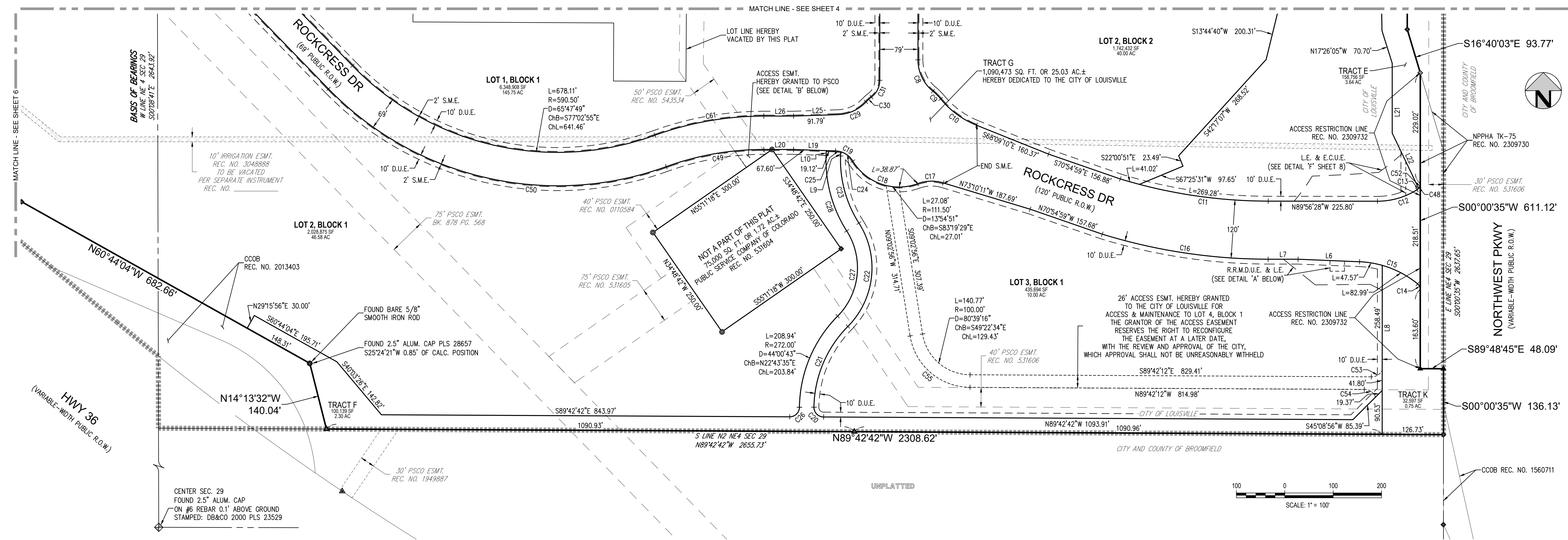

FINAL SUBDIVISION PLAT OF  
**REDTAIL RIDGE FILING NO. 1**  
 SITUATED IN THE SOUTH HALF OF SECTION 20 AND THE NORTH HALF OF SECTION 29, TOWNSHIP 1 SOUTH,  
 RANGE 69 WEST OF THE SIXTH PRINCIPAL MERIDIAN, CITY OF LOUISVILLE, COUNTY OF BOULDER, STATE OF COLORADO  
 PLAT SHEET

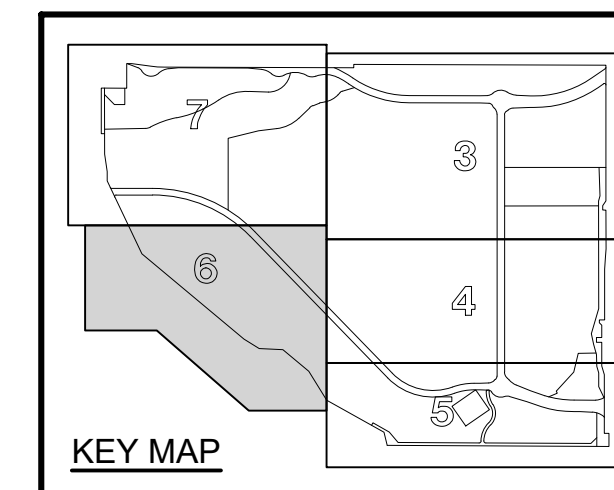

PREPARED BY:  
**HKS HARRIS KOCHER SMITH**  
 1120 Lincoln Street, Suite 1000  
 Denver, Colorado 80203  
 P: 303-623-6300 F: 303-623-6311  
 HarrisKocherSmith.com

NO CHANGES ARE TO BE MADE TO THIS DRAWING WITHOUT WRITTEN PERMISSION OF HARRIS KOCHER SMITH.

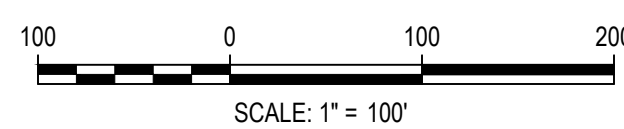
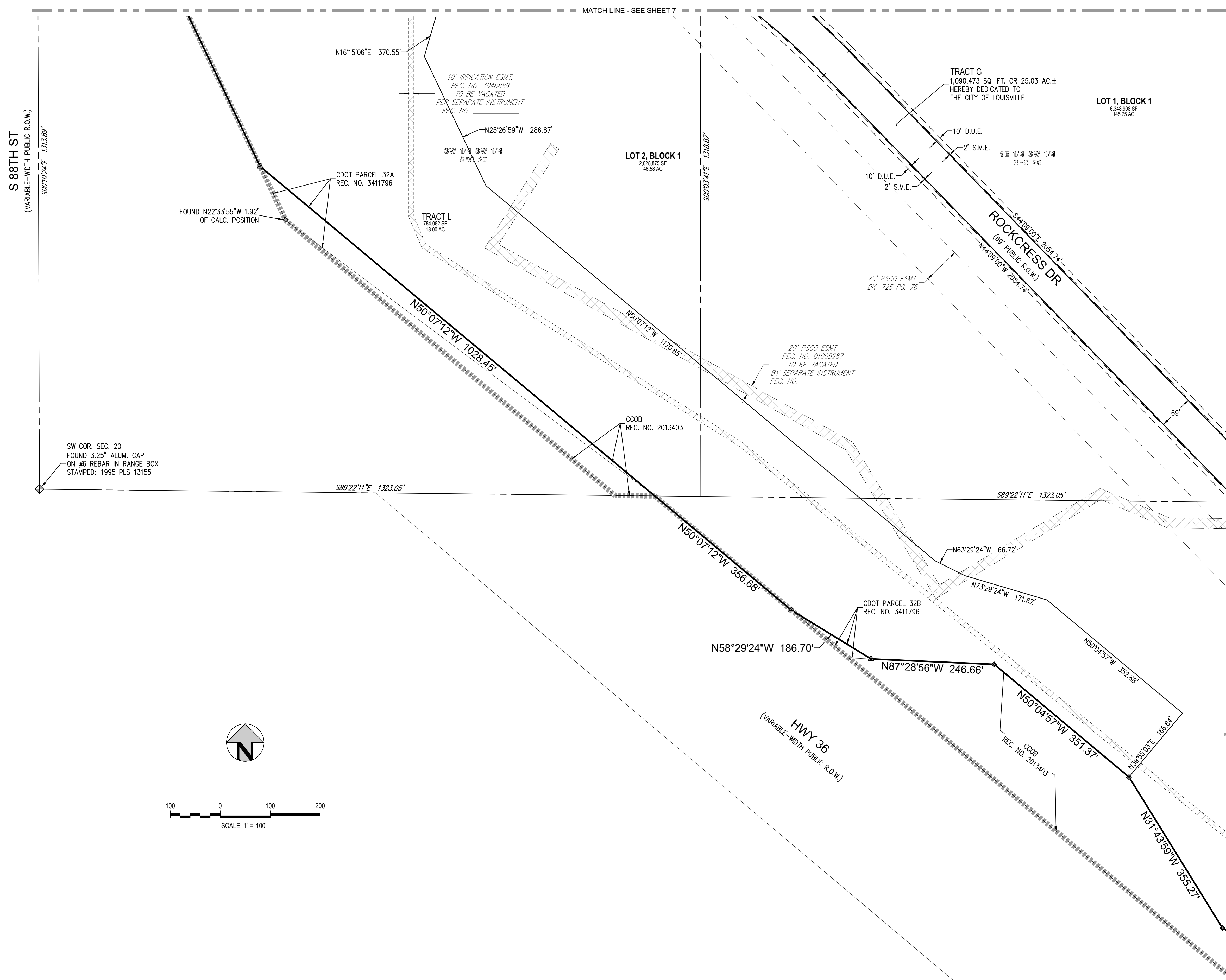

FILEPATH: P:\180108\SUBDIVISION\PLAT\FINAL\DWG\DELETED\DWG LAYOUT\_SHT 6  
 5\_XREFS: (none)  
 6\_XREFS: (none)  
 7\_XREFS: (none)  
 8\_XREFS: (none)  
 9\_XREFS: (none)  
 10\_XREFS: (none)  
 11\_XREFS: (none)  
 12\_XREFS: (none)  
 13\_XREFS: (none)  
 14\_XREFS: (none)  
 15\_XREFS: (none)  
 16\_XREFS: (none)  
 17\_XREFS: (none)  
 18\_XREFS: (none)  
 19\_XREFS: (none)  
 20\_XREFS: (none)  
 21\_XREFS: (none)  
 22\_XREFS: (none)  
 23\_XREFS: (none)  
 24\_XREFS: (none)  
 25\_XREFS: (none)  
 26\_XREFS: (none)  
 27\_XREFS: (none)  
 28\_XREFS: (none)  
 29\_XREFS: (none)  
 30\_XREFS: (none)  
 31\_XREFS: (none)  
 32\_XREFS: (none)  
 33\_XREFS: (none)  
 34\_XREFS: (none)  
 35\_XREFS: (none)  
 36\_XREFS: (none)  
 37\_XREFS: (none)  
 38\_XREFS: (none)  
 39\_XREFS: (none)  
 40\_XREFS: (none)  
 41\_XREFS: (none)  
 42\_XREFS: (none)  
 43\_XREFS: (none)  
 44\_XREFS: (none)  
 45\_XREFS: (none)  
 46\_XREFS: (none)  
 47\_XREFS: (none)  
 48\_XREFS: (none)  
 49\_XREFS: (none)  
 50\_XREFS: (none)  
 51\_XREFS: (none)  
 52\_XREFS: (none)  
 53\_XREFS: (none)  
 54\_XREFS: (none)  
 55\_XREFS: (none)  
 56\_XREFS: (none)  
 57\_XREFS: (none)  
 58\_XREFS: (none)  
 59\_XREFS: (none)  
 60\_XREFS: (none)  
 61\_XREFS: (none)  
 62\_XREFS: (none)  
 63\_XREFS: (none)  
 64\_XREFS: (none)  
 65\_XREFS: (none)  
 66\_XREFS: (none)  
 67\_XREFS: (none)  
 68\_XREFS: (none)  
 69\_XREFS: (none)  
 70\_XREFS: (none)  
 71\_XREFS: (none)  
 72\_XREFS: (none)  
 73\_XREFS: (none)  
 74\_XREFS: (none)  
 75\_XREFS: (none)  
 76\_XREFS: (none)  
 77\_XREFS: (none)  
 78\_XREFS: (none)  
 79\_XREFS: (none)  
 80\_XREFS: (none)  
 81\_XREFS: (none)  
 82\_XREFS: (none)  
 83\_XREFS: (none)  
 84\_XREFS: (none)  
 85\_XREFS: (none)  
 86\_XREFS: (none)  
 87\_XREFS: (none)  
 88\_XREFS: (none)  
 89\_XREFS: (none)  
 90\_XREFS: (none)  
 91\_XREFS: (none)  
 92\_XREFS: (none)  
 93\_XREFS: (none)  
 94\_XREFS: (none)  
 95\_XREFS: (none)  
 96\_XREFS: (none)  
 97\_XREFS: (none)  
 98\_XREFS: (none)  
 99\_XREFS: (none)  
 100\_XREFS: (none)



# REDTAIL RIDGE FILING NO. 1

SITUATED IN THE SOUTH HALF OF SECTION 20 AND THE NORTH HALF OF SECTION 29, TOWNSHIP 1 SOUTH, RANGE 69 WEST OF THE SIXTH PRINCIPAL MERIDIAN, CITY OF LOUISVILLE, COUNTY OF BOULDER, STATE OF COLORADO  
PLAT SHEET

PREPARED BY:

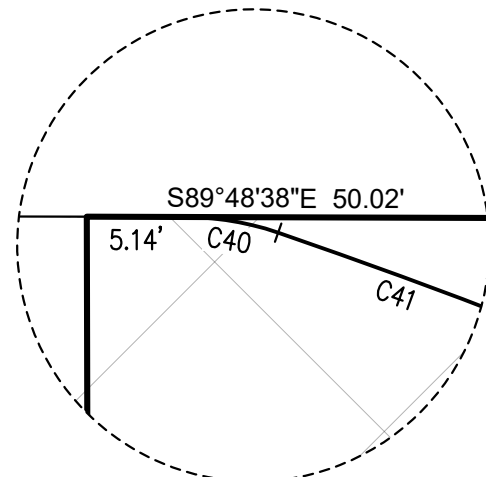
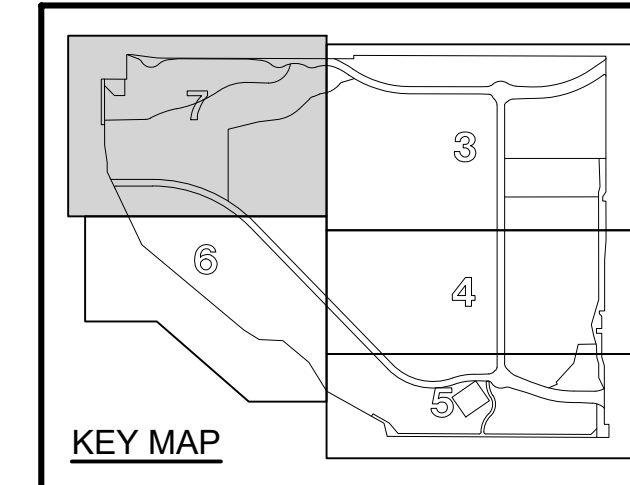

DETAIL 'C'  
1" = 10'

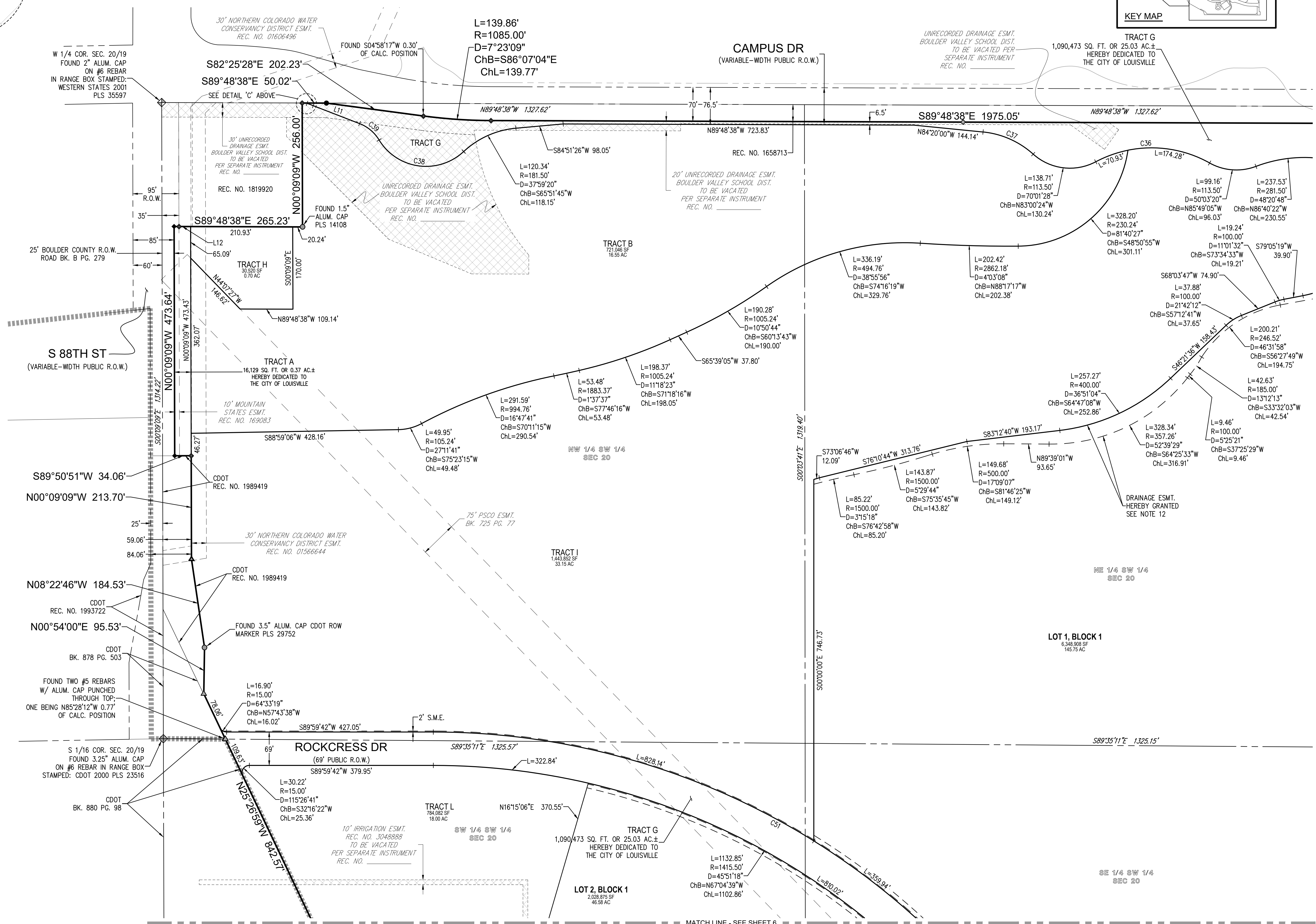

NO CHANGES ARE TO BE MADE TO THIS DRAWING WITHOUT WRITTEN PERMISSION OF HARRIS KOCHER SMITH.

MATCH LINE - SEE SHEET 3

MATCH LINE - SEE SHEET 6

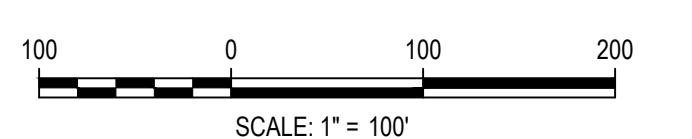
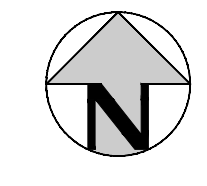

SCALE: 1" = 100'

FINAL SUBDIVISION PLAT OF  
**REDTAIL RIDGE FILING NO. 1**  
 SITUATED IN THE SOUTH HALF OF SECTION 20 AND THE NORTH HALF OF SECTION 29, TOWNSHIP 1 SOUTH,  
 RANGE 69 WEST OF THE SIXTH PRINCIPAL MERIDIAN, CITY OF LOUISVILLE, COUNTY OF BOULDER, STATE OF COLORADO  
 EASEMENT DETAILS 'D', 'E' & 'F'

PREPARED BY:  
**HKS HARRIS KOCHER SMITH**  
 1120 Lincoln Street, Suite 1000  
 Denver, Colorado 80203  
 P: 303-623-6300 F: 303-623-6311  
 HarrisKocherSmith.com

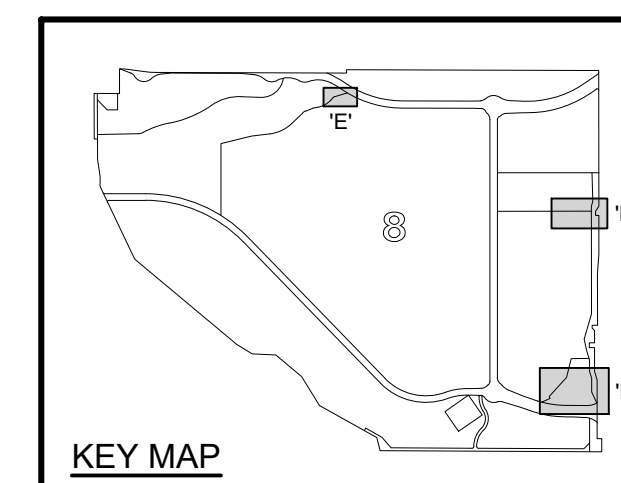

**DETAIL 'D'**  
 SCALE: 1" = 60'

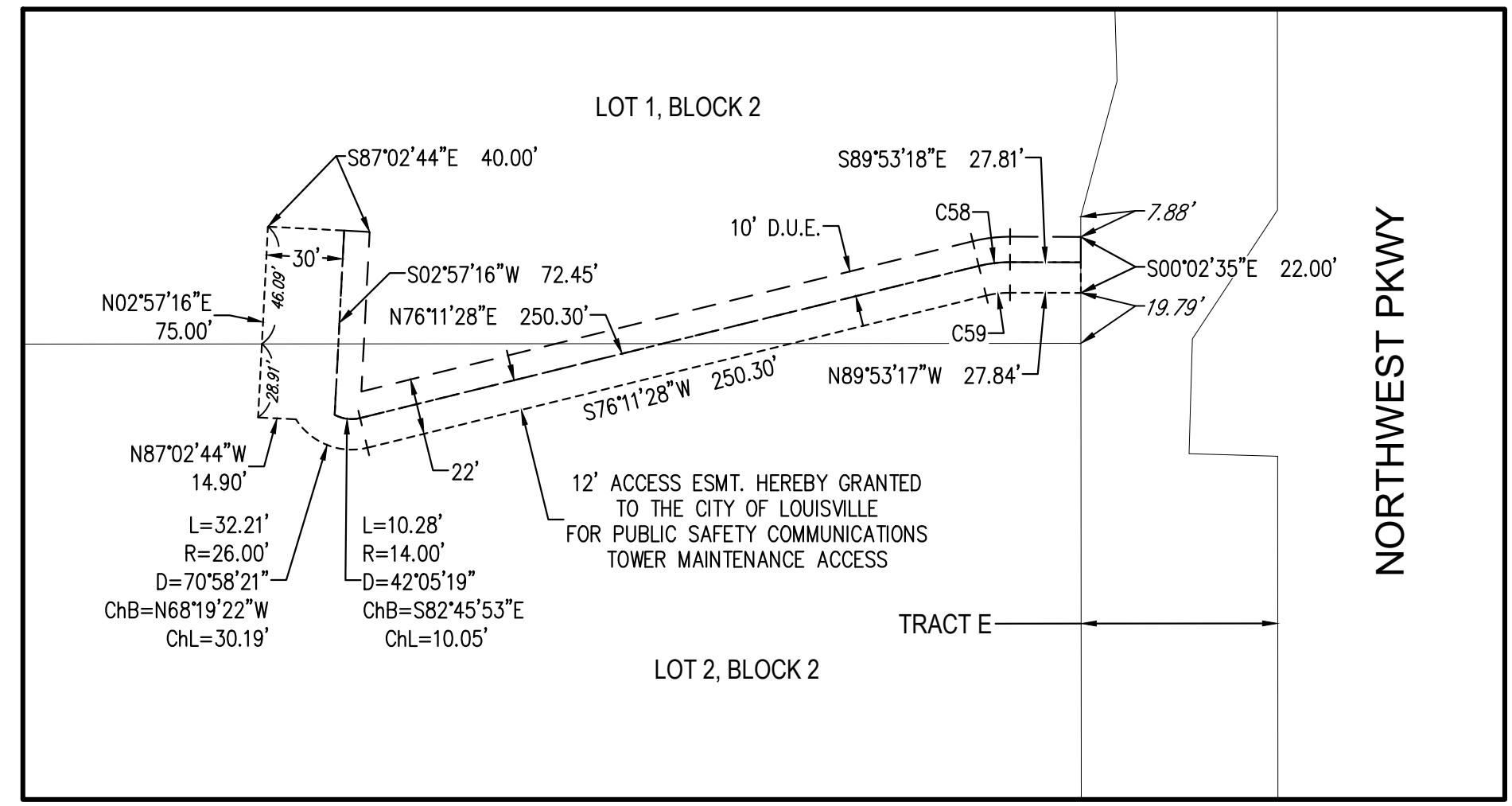

**DETAIL 'E'**  
 SCALE: 1" = 40'

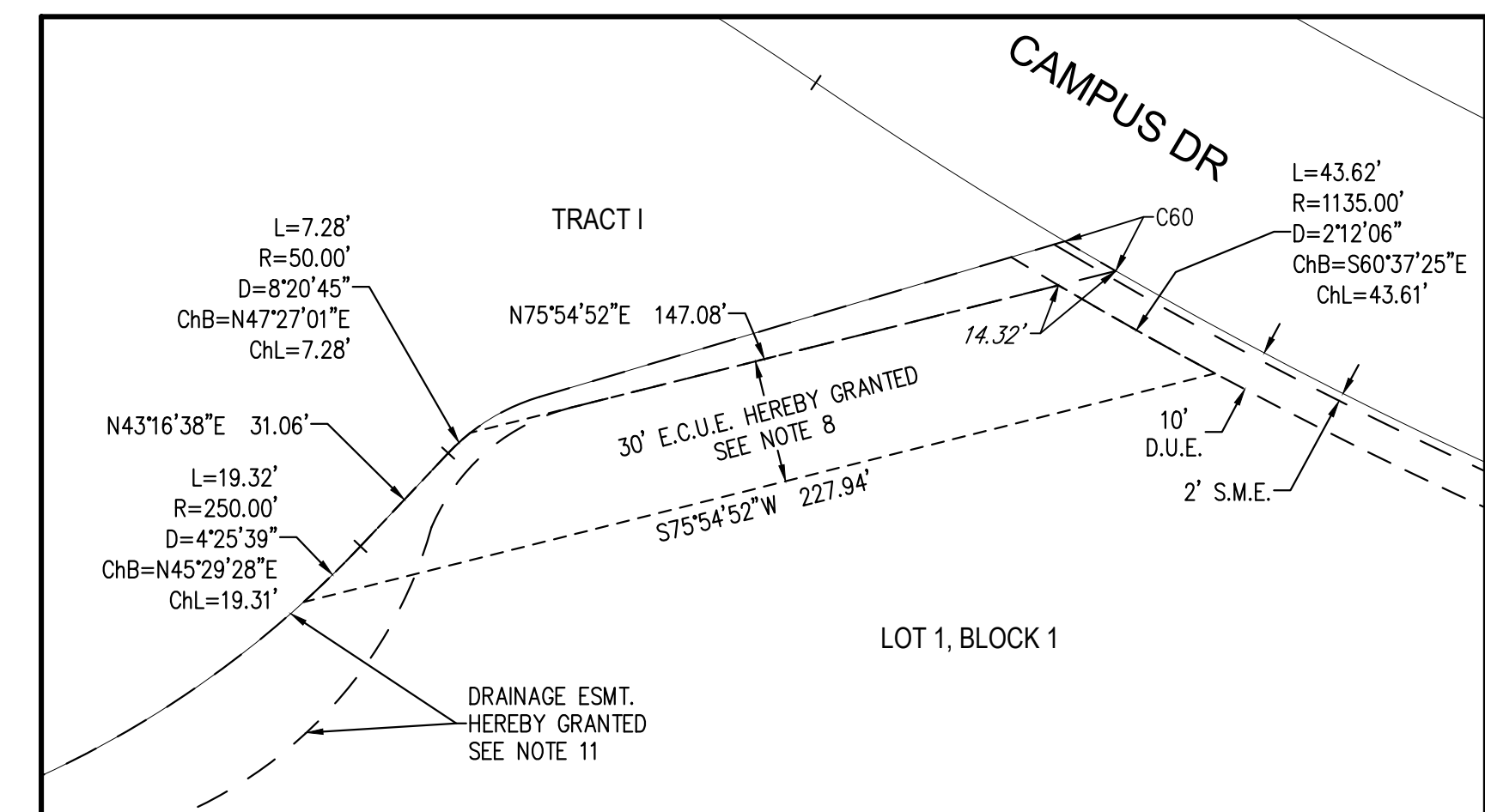

**DETAIL 'F'**  
 SCALE: 1" = 60'

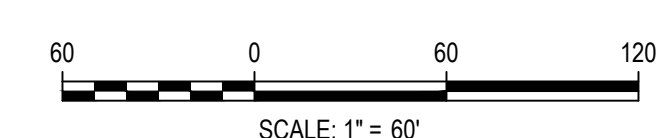
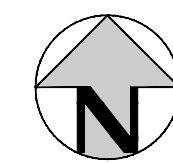
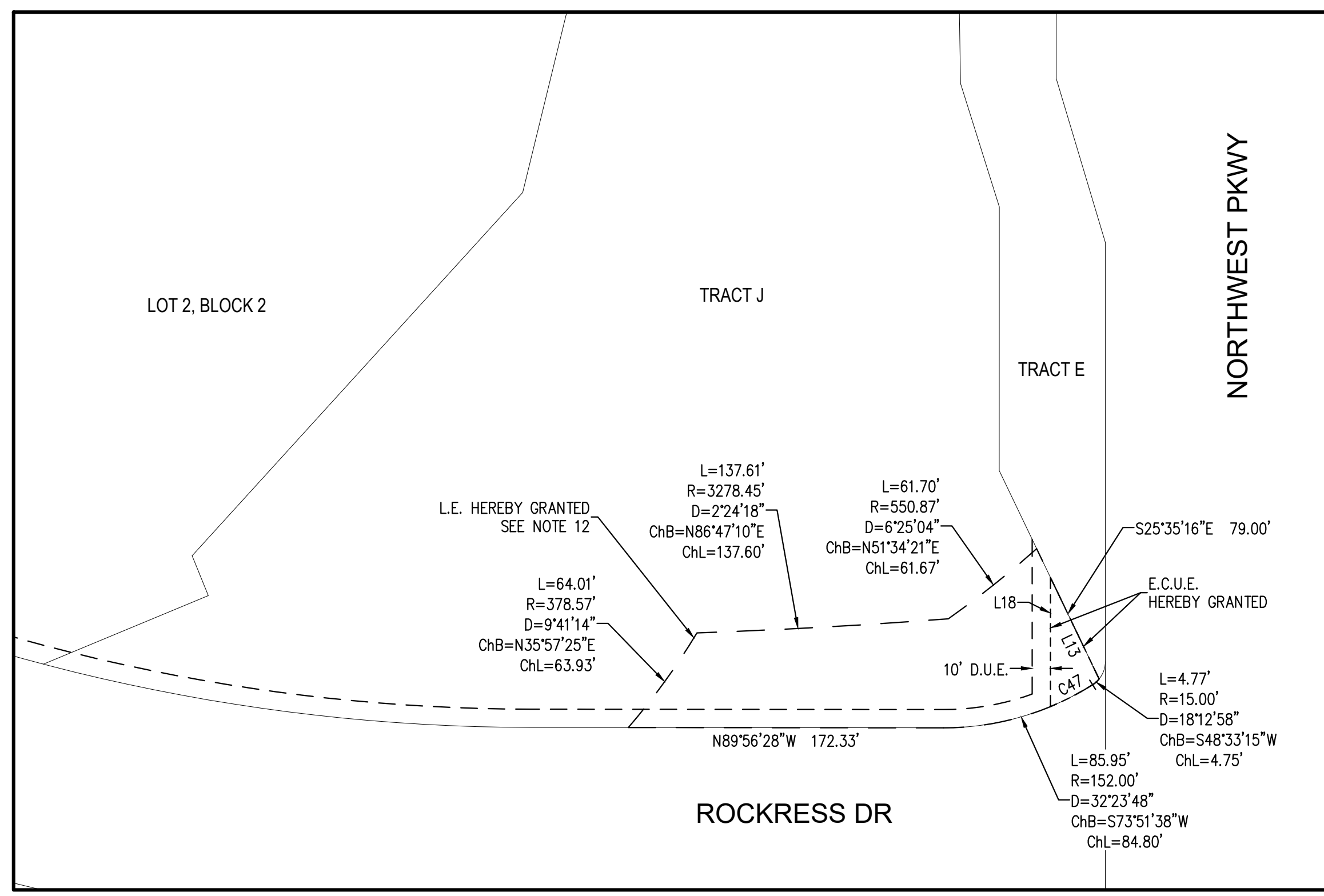

NO CHANGES ARE TO BE MADE TO THIS DRAWING WITHOUT WRITTEN PERMISSION OF HARRIS KOCHER SMITH.

FILEPATH: P:\180108\SUBDIVISION\PLAT\180108.DWG TO DELETE DWG LAYOUT: SHT 8  
 5: XREF: (none)  
 6: XREF: (none)  
 7: XREF: (none)  
 8: XREF: (none)  
 9: XREF: (none)  
 10: XREF: (none)  
 11: XREF: (none)  
 12: XREF: (none)  
 13: XREF: (none)  
 14: XREF: (none)  
 15: XREF: (none)  
 16: XREF: (none)  
 17: XREF: (none)  
 18: XREF: (none)  
 19: XREF: (none)  
 20: XREF: (none)  
 21: XREF: (none)  
 22: XREF: (none)  
 23: XREF: (none)  
 24: XREF: (none)  
 25: XREF: (none)  
 26: XREF: (none)  
 27: XREF: (none)  
 28: XREF: (none)  
 29: XREF: (none)  
 30: XREF: (none)  
 31: XREF: (none)  
 32: XREF: (none)  
 33: XREF: (none)  
 34: XREF: (none)  
 35: XREF: (none)  
 36: XREF: (none)  
 37: XREF: (none)  
 38: XREF: (none)  
 39: XREF: (none)  
 40: XREF: (none)  
 41: XREF: (none)  
 42: XREF: (none)  
 43: XREF: (none)  
 44: XREF: (none)  
 45: XREF: (none)  
 46: XREF: (none)  
 47: XREF: (none)  
 48: XREF: (none)  
 49: XREF: (none)  
 50: XREF: (none)  
 51: XREF: (none)  
 52: XREF: (none)  
 53: XREF: (none)  
 54: XREF: (none)  
 55: XREF: (none)  
 56: XREF: (none)  
 57: XREF: (none)  
 58: XREF: (none)  
 59: XREF: (none)  
 60: XREF: (none)  
 61: XREF: (none)  
 62: XREF: (none)  
 63: XREF: (none)  
 64: XREF: (none)  
 65: XREF: (none)  
 66: XREF: (none)  
 67: XREF: (none)  
 68: XREF: (none)  
 69: XREF: (none)  
 70: XREF: (none)  
 71: XREF: (none)  
 72: XREF: (none)  
 73: XREF: (none)  
 74: XREF: (none)  
 75: XREF: (none)  
 76: XREF: (none)  
 77: XREF: (none)  
 78: XREF: (none)  
 79: XREF: (none)  
 80: XREF: (none)  
 81: XREF: (none)  
 82: XREF: (none)  
 83: XREF: (none)  
 84: XREF: (none)  
 85: XREF: (none)  
 86: XREF: (none)  
 87: XREF: (none)  
 88: XREF: (none)  
 89: XREF: (none)  
 90: XREF: (none)  
 91: XREF: (none)  
 92: XREF: (none)  
 93: XREF: (none)  
 94: XREF: (none)  
 95: XREF: (none)  
 96: XREF: (none)  
 97: XREF: (none)  
 98: XREF: (none)  
 99: XREF: (none)  
 100: XREF: (none)



NO CHANGES ARE TO BE MADE TO THIS DRAWING WITHOUT WRITTEN PERMISSION OF HARRIS KOCHER SMITH.

FINAL SUBDIVISION PLAT OF  
**REDTAIL RIDGE FILING NO. 1**  
 SITUATED IN THE SOUTH HALF OF SECTION 20 AND THE NORTH HALF OF SECTION 29, TOWNSHIP 1 SOUTH,  
 RANGE 69 WEST OF THE SIXTH PRINCIPAL MERIDIAN, CITY OF LOUISVILLE, COUNTY OF BOULDER, STATE OF COLORADO  
 LINE & CURVE TABLES

PREPARED BY:  
  
 1120 Lincoln Street, Suite 1000  
 Denver, Colorado 80203  
 P: 303-623-6300 F: 303-623-6311  
 HarrisKocherSmith.com

CURVE TABLE					
CURVE	RADIUS	DELTA	LENGTH	CHORD BEARING	CHORD
C1	1170.00'	10°53'44"	222.49'	S61°06'53"E	222.15'
C2	1050.00'	34°52'33"	639.13'	N72°44'53"E	629.31'
C3	15.00'	55°20'51"	14.49'	N27°38'12"E	13.93'
C4	15.00'	124°39'10"	32.63'	N62°21'48"W	26.57'
C5	78.00'	39°42'30"	54.06'	S68°04'42"W	52.98'
C6	117.00'	10°56'24"	22.34'	S53°41'39"W	22.31'
C7	42.00'	59°09'51"	43.37'	S29°34'56"W	41.47'
C8	83.50'	50°53'35"	74.17'	S25°26'48"E	71.75'
C9	111.50'	11°36'40"	22.60'	S45°05'15"E	22.56'
C10	184.50'	28°52'15"	92.97'	S53°43'03"E	91.99'
C11	1050.00'	16°55'55"	310.29'	S81°28'31"E	309.16'
C12	152.00'	32°23'48"	85.95'	N73°51'38"E	84.80'
C13	15.00'	181°2'58"	4.77'	N48°33'15"E	4.75'
C14	15.00'	50°38'48"	13.26'	N25°18'48"W	12.83'
C15	202.00'	37°01'56"	130.56'	N69°09'09"W	128.30'
C16	1170.00'	17°02'32"	348.01'	N81°25'12"W	346.72'
C17	83.50'	37°05'08"	54.05'	S88°17'15"W	53.11'
C18	111.50'	78°59'15"	153.71'	N70°45'42"W	141.83'
C19	43.50'	56°44'14"	43.08'	N59°38'11"W	41.34'
C20	20.00'	90°34'06"	31.61'	N44°25'39"W	28.42'
C21	242.00'	43°52'33"	185.32'	N22°47'40"E	180.82'
C22	172.00'	77°16'43"	231.99'	N06°05'35"E	214.80'
C23	242.00'	34°32'28"	145.89'	N15°16'32"W	143.69'
C24	43.50'	42°15'22"	32.08'	N52°23'45"W	31.36'
C25	43.50'	14°28'51"	10.99'	N80°45'52"W	10.96'
C26	20.00'	89°34'04"	31.27'	N45°30'15"E	28.18'
C27	142.00'	77°16'43"	191.52'	N06°05'35"E	177.33'
C28	272.00'	34°32'28"	163.98'	N15°16'32"W	161.51'
C29	83.50'	44°43'21"	65.18'	N65°43'56"E	63.53'
C30	93.50'	9°20'23"	15.24'	N48°02'27"E	15.22'
C31	43.50'	52°42'39"	40.02'	N26°21'19"E	38.62'
C32	83.50'	46°35'42"	67.91'	N23°17'51"W	66.05'
C33	95.50'	21°02'24"	35.07'	N36°04'30"W	34.87'
C34	41.50'	62°23'18"	45.19'	N56°44'58"W	42.99'
C35	1125.00'	34°08'49"	670.47'	N72°44'26"W	660.60'
C36	245.50'	57°13'43"	245.21'	N89°24'17"W	235.15'
C37	181.50'	36°20'19"	115.11'	N66°09'50"W	113.19'
C38	113.50'	101°55'25"	201.91'	N82°10'12"W	176.32'
C39	81.50'	37°38'17"	53.54'	N50°01'38"W	52.58'
C40	15.00'	18°48'26"	4.92'	N80°24'26"W	4.90'
C41	361.50'	2°09'26"	13.61'	N69°55'30"W	13.61'
C42	250.00'	35°48'41"	156.26'	S61°10'59"W	153.73'
C43	50.00'	30°12'49"	26.37'	S58°23'03"W	26.06'
C44	107.49'	62°59'40"	118.18'	S47°05'59"W	112.32'
C45	50.00'	53°05'40"	46.33'	S49°22'03"W	44.69'
C46	1170.00'	34°52'33"	712.18'	S72°44'53"W	701.23'
C47	152.00'	9°47'34"	25.98'	S62°33'31"W	25.95'
C48	15.00'	57°39'09"	15.09'	N28°50'10"E	14.46'
C49	590.50'	19°56'31"	205.53'	S80°01'26"W	204.49'
C50	659.50'	65°47'49"	757.35'	S77°02'55"E	716.42'
C51	1484.50'	45°51'18"	1188.07'	N67°04'39"W	1156.62'
C52	15.00'	39°26'11"	10.32'	N19°43'41"E	10.12'
C53	25.00'	63°06'26"	27.54'	N58°44'35"E	26.16'
C54	25.00'	68°31'15"	29.90'	N55°26'34"W	28.15'

CURVE TABLE					
CURVE	RADIUS	DELTA	LENGTH	CHORD BEARING	CHORD
C55	126.00'	80°39'16"	177.37'	N49°22'34"W	163.08'
C56	1170.00'	3°15'57"	66.69'	N58°21'14"E	66.68'
C57	1050.00'	3°44'50"	68.67'	S61°34'41"W	68.66'
C58	51.00'	13°55'15"	12.39'	N83°09'06"E	12.36'
C59	39.00'	13°55'15"	9.48'	S83°09'06"W	9.45'
C60	1125.00'	0°43'40"	14.29'	S59°40'42"E	14.29'
C61	659.50'	19°56'31"	229.54'	S80°01'26"W	228.38'

LINE TABLE		
LINE	BEARING	LENGTH
L1	N89°42'42"W	55.73'
L2	S00°00'35"W	30.02'
L3	S44°51'26"E	35.44'
L4	S00°00'35"W	127.21'
L5	N89°59'25"W	55.00'
L6	N87°40'08"W	127.24'
L7	N89°56'28"W	61.81'
L8	N00°01'40"E	349.02'
L9	N01°59'42"E	8.65'
L10	N01°59'42"E	10.03'
L11	N88°50'46"W	102.75'
L12	S89°48'38"E	34.06'
L13	S25°35'16"E	61.53'
L14	S43°16'38"W	31.06'
L15	S73°29'27"W	132.85'
L16	S79°34'31"W	118.46'
L17	S75°54'52"W	136.13'
L18	N00°00'35"E	70.60'
L19	N88°00'18"W	86.72'
L20	S89°59'42"W	61.55'
L21	N00°00'35"E	144.24'
L22	N25°35'16"W	126.34'
L23	S57°30'42"E	123.02'
L24	N57°30'42"W	190.37'
L25	N88°05'36"E	91.79'
L26	N89°59'42"E	61.57'

FILEPATH: P:\180108\SUBDIVISION\PLAT\180108.DWG TO DELETE.DWG LAYOUT: SHT 9  
 5: XREF: (none)  
 6: XREF: (none)  
 7: XREF: (none)  
 8: XREF: (none)  
 9: XREF: (none)  
 10: XREF: (none)  
 11: XREF: (none)  
 12: XREF: (none)  
 13: XREF: (none)  
 14: XREF: (none)  
 15: XREF: (none)  
 16: XREF: (none)  
 17: XREF: (none)  
 18: XREF: (none)  
 19: XREF: (none)  
 20: XREF: (none)  
 21: XREF: (none)  
 22: XREF: (none)  
 23: XREF: (none)  
 24: XREF: (none)  
 25: XREF: (none)  
 26: XREF: (none)  
 27: XREF: (none)  
 28: XREF: (none)  
 29: XREF: (none)  
 30: XREF: (none)  
 31: XREF: (none)  
 32: XREF: (none)  
 33: XREF: (none)  
 34: XREF: (none)  
 35: XREF: (none)  
 36: XREF: (none)  
 37: XREF: (none)  
 38: XREF: (none)  
 39: XREF: (none)  
 40: XREF: (none)  
 41: XREF: (none)  
 42: XREF: (none)  
 43: XREF: (none)  
 44: XREF: (none)  
 45: XREF: (none)  
 46: XREF: (none)  
 47: XREF: (none)  
 48: XREF: (none)  
 49: XREF: (none)  
 50: XREF: (none)  
 51: XREF: (none)  
 52: XREF: (none)  
 53: XREF: (none)  
 54: XREF: (none)  
 55: XREF: (none)  
 56: XREF: (none)  
 57: XREF: (none)  
 58: XREF: (none)  
 59: XREF: (none)  
 60: XREF: (none)  
 61: XREF: (none)  
 62: XREF: (none)  
 63: XREF: (none)  
 64: XREF: (none)  
 65: XREF: (none)  
 66: XREF: (none)  
 67: XREF: (none)  
 68: XREF: (none)  
 69: XREF: (none)  
 70: XREF: (none)  
 71: XREF: (none)  
 72: XREF: (none)  
 73: XREF: (none)  
 74: XREF: (none)  
 75: XREF: (none)  
 76: XREF: (none)  
 77: XREF: (none)  
 78: XREF: (none)  
 79: XREF: (none)  
 80: XREF: (none)  
 81: XREF: (none)  
 82: XREF: (none)  
 83: XREF: (none)  
 84: XREF: (none)  
 85: XREF: (none)  
 86: XREF: (none)  
 87: XREF: (none)  
 88: XREF: (none)  
 89: XREF: (none)  
 90: XREF: (none)  
 91: XREF: (none)  
 92: XREF: (none)  
 93: XREF: (none)  
 94: XREF: (none)  
 95: XREF: (none)  
 96: XREF: (none)  
 97: XREF: (none)  
 98: XREF: (none)  
 99: XREF: (none)  
 100: XREF: (none)